

Leader in Interactive Boards for Education in Portugal.
More than 8000 systems installed in schools.



netboard

MOBILE

= INTERACTIVE BOARD + PROJECTOR + PC
(just plug it in, without any installation)



- Interactive board 78" with anti-reflection stand
- Short throw projector
- Integrated computer with keyboard
- Height adjustable stand with rotating arm
- Enhanced adaptability and security



netboard

WALL



Stands with solid structure in Ø50x2mm and 60x20x1,5mm steel tubes, with a high resistance epoxy powder coating. Equipment fully lockable using Kensington type locks. Feet and exposed terminals in polyamide. Hardware and IT components to be determined.

The interactive boards **ACTIVBOARD 178** have a passive electromagnetic interface with resistant melamine covering, ideal for low-glare. Series connection RS232 to allow a maximum of 38,4 kbs or USB 1.1/2. Includes battery-free and wireless ActivPen. **Internal resolution** 2730 points/inch **Tracking rate** 200 inches/sec. **Output rate** 120 coordinate pairs/sec. **Warranty** 3 years on location, 5 years surface

EPSON EB-410W, the ultra-short throw projector for interactive business presentations. **Native resolution** WXGA (1280x800) **Brightness** 2000 ANSI lm **Contrast ratio** 500:1 **Warranty** 3 years, lamp included

+ 3 YEARS WARRANTY (consumer)



WIFI



2
YEAR
GUARANTEE



100%
RECYCLABLE



Worlddidac Award 2008
World Award for Innovation in Education

REGISTERED MODEL
No 001632720-001
MODELO REGISTRADO

NBMR1

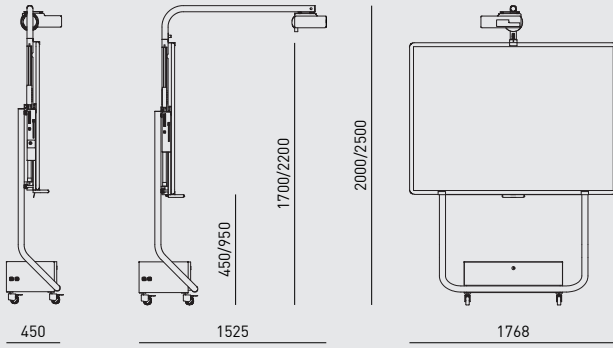

NBPR1

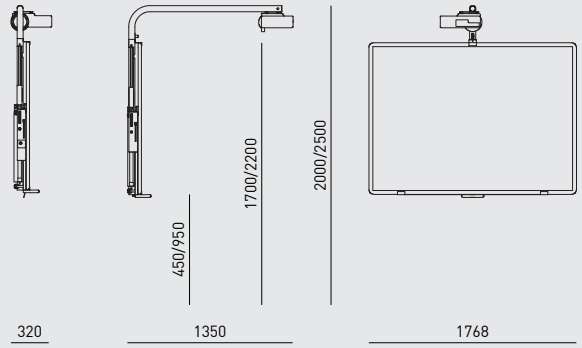

NBPF1

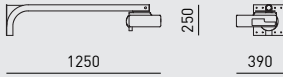

AB178

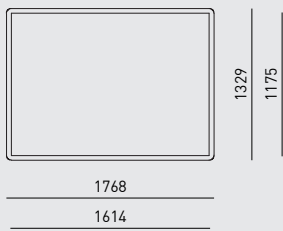

VP410W



ORDERS:

Telephone: +351 224 507 420

Fax: +351 224 507 429

E-mail: vendas@nautilus.pt

More informations on **NETBOARD** available on the website: www.escolainteractiva.com

POWERED BY:



SUPPORTED BY:





GRUPO NAUTILUS

Rua Nossa Senhora da Livração, 1250-1300 – Esposade Apartado 162 / 4515-161 Foz do Sousa / Portugal
Tel. +351 224 507 420 / Fax +351 224 507 429
geral@nautilus.pt / www.nautilus.pt

Rua da Garagem, nº 14
Urbanização Industrial da Barruncheira
Apartado 1106 / 2790-078 Carnaxide – Oeiras
Tel. +351 214 121 993 / Fax +351 214 121 995

METALLIC STRUCTURE

	Anthracite	(RAL 7021)
	Grey	(RAL 7037)

These colours may have deviations due to the printing process .
Mentioned brands are property of their respective owners.

